

VEHICLE DETAILS

Chassis number ¹: PE8W-0303853

Manufacture date: 1997-09

Make: MITSUBISHI

Model: DELICA SPACE GEAR

Body: KD-PE8W

Grade: CHAMONIX

Engine: 4M40

Drive: 4WD

Transmission: AT

Title information ²:



Deregistered to Export



Accident / Repair:



No problem



Odometer rollback:



No problem



Manufacturer recall:



No problem



Safety grade ³:



No data



Contamination risk:



No problem



This vehicle does not qualify for Buyback Guarantee



Unfortunately, this vehicle does not qualify for our Buyback Guarantee program.

[About Buyback Guarantee](#)

Average Market Price



¥400,000

This CAR VX Vehicle History Report is based only on Information supplied to CAR VX, LTD and available as of 2023-09-15 22:02:13. Other information about this vehicle, including problems, may not have been reported to CAR VX, LTD . Use this report as one important tool, along with a vehicle inspection and test drive, to make a better decision about your next used car.

ACCIDENT / REPAIR HISTORY

Problem type	Reported	Date reported	Data source	Details	Airbag
Collision	✔ Not reported				
Malfunction	✔ Not reported				
Theft	✔ Not reported				
Fire damage	✔ Not reported				
Water damage	✔ Not reported				
Hail damage	✔ Not reported				

ODOMETER READINGS HISTORY

Date reported	Data source	Odometer reading (Km)
2018-12-05	MLIT	164100
2020-12-17	MLIT	171900
2022-12-22	USS Tokyo	179138

USE HISTORY

Use in the contaminated regions ⁴	Radioactive contamination test fail ⁵	Commercial use
✔ Not reported	✔ Not reported	✔ Not reported

DETAILED HISTORY

Event date	Location	Odometer reading (Km)	Data source	Details
1997-09			MITSUBISHI	Manufactured
1997-10			MLIT	First registration
2018-12-05		164100	MLIT	Inspection
2020-12-17	Mito	171900	MLIT	Inspection
2022-12-14	Mito		MLIT	Last registration

MANUFACTURER RECALL HISTORY

Date reported	Data source	Affected part	Details
 Not reported			

VEHICLE ASSESSMENT ⁶

Overall Collision Safety Ratings

Driver's seat			Front passenger's seat		
Points	Evaluation	Goal average	Points	Evaluation	Goal average
0		0%	0		0%

* In order to accurately differentiate between the evaluations of different vehicles, a standard is set based on current technology. Up to 6 points out of 12 is given level 1 and the rest of the range is divided up into equal parts, which are respectively assigned to level 2 (more than 6 points but 7.5 or less), level 3 (more than 7.5 points but 9 or less), level 4 (more than 9 points but 10.5 or less) or level 5 (more than 10.5 points).

Braking performance tests ⁷

Dry road



Wet road



VEHICLE SPECIFICATION

1st gear ratio

2nd gear ratio

3rd gear ratio

4th gear ratio

5th gear ratio

6th gear ratio

Additional notes

Airbag position,
capacity

Body rear overhang

Body type

Station Wagon

Chassis number embossing position		Classification code	128
Cylinders	4	Displacement	2830
Electric engine type		Electric engine maximum output	
Electric engine maximum torque		Electric engine power	
Engine maximum power	140ps(103kW)/4000rpm	Engine maximum torque	32.0kg· m(313.8N· m)/2000rpm
Engine model	4M40	Frame type	
Front shaft weight	1240	Front shock absorber type	
Front stabilizer type		Front tires size	225/80R15
Front tread	1440	Fuel consumption	
Fuel tank equipment	75	Grade	CHAMONIX
Height	206	Length	468
Main brakes type		Make	MITSUBISHI
Maximum speed		Minimum ground clearance	
Minimum turning radius	6.0	Model	DELICA SPACE GEAR
Model code	KD-PE8W	Mufflers number	
Rear shaft weight	790	Rear shock absorber type	
Rear stabilizer type		Rear tires size	225/80R15
Rear tread	1435	Reverse ratio	
Riding capacity	8	Side brakes type	
Specification code	7642	Stopping distance	
Transmission type	AT	Weight	2030
Wheel alignment	4WD	Wheelbase	2800
Width	169		

Date: 2022-12-22, Auction: USS Tokyo, Lot #: 35181

Date:	2022-12-22	Lot #:	35181
Auction name:	USS Tokyo	Region:	Chiba
Make:	MITSUBISHI	Model:	DELICA SPACE GEAR
Reg. year:	1997	Mileage (km):	179138
Displacement (cc):	2800	Transmission:	CA
Color:	BLACK 2	Model code:	PE8W
Result:	available	Auction grade:	3.5
Problem type:	No problem	Problem scale:	None
Contaminated:	No	Airbag:	OK

PHOTOS AND AUCTION SHEETS

スライドコーナー

35181	型式	2000 KD-PE2W	排気量	2000
	初年度登録年月	17/10月	グレード	シロミー
	車名	770 スイースト	駆動方式	2WD
	内装	B		

車検	年	月	ソフト	CAT	SR	純AW	CS	CV
走行	179138	Km	冷房	AC	カワ	TV	ナビ	CPB
外色	705	色番	カラー	X08A+6	セールスポイント			
燃料	ガソリン	内装色	無					
輸入区分	ディーラー並行	ハンドル	左	右				

リサイクル料	15,370円	乗車定員	8人	登録地	
車台番号	PE2W-0505883	シリアル			

○注意事項 (検査 不具合箇所および状態)

○検査員報告 (USS使用欄)

右前-変換不良 4? AW
 フリムワ 22.0V27
 フロント 多子ボルト
 ルーム(部) 下回り
 22.0V-27
 [階台内寸] 幅 x x (cm)
 長さ x68 cm 幅 169 cm 高さ x06 cm (車検証上の寸法)

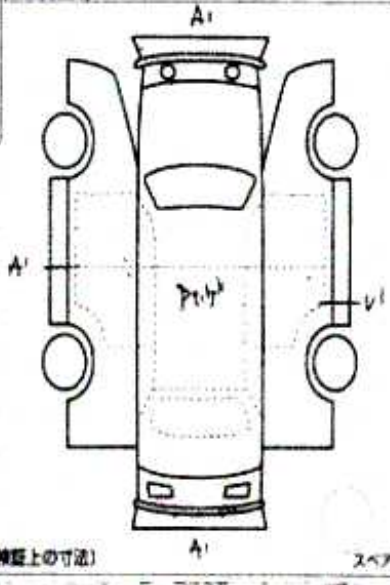



¹ Chassis number – a unique identification number of the vehicle in Japan (same as VIN in the USA or Europe)

² Title information:

Registered – qualified for driving in Japan

Deregistered Temporarily – not qualified for driving in Japan, usually a temporary title during the ownership change

Deregistered Completely – not qualified for driving in Japan, the vehicle is determined to be scrapped

Deregistered to Export – not qualified for driving in Japan, the vehicle is determined to be exported

³ Determining the overall collision safety performance evaluation – For the driver's seat, the results of the full-wrap frontal collision test, offset frontal collision test, and side collision test are added together and evaluated to 6 different levels. For the Frontal passenger's seat, the results of the full-wrap frontal collision test and the side collision test (results for the driver's or the front passenger's seat are used) are added together and evaluated to 6 different levels.

Regular vehicle inspection – All vehicles in Japan must undergo regular vehicle inspections (shaken). New cars need to be tested after three years, and then vehicles must be tested every two years thereafter. A vehicle inspection (shaken) is compulsory for all vehicles with an engine size over 250cc. It ensures that all vehicles on the road are properly maintained and safe to drive. The test also checks that vehicles have not been illegally modified; if they are found to have been modified, they are not allowed on the road.

⁴ Use in the contaminated regions – The Fukushima Daiichi nuclear disaster was a catastrophic failure at the Fukushima I Nuclear Power Plant on 11 March 2011, resulting in a meltdown of three of the plant's six nuclear reactors. As a result, some areas in the following prefectures were contaminated: Fukushima, Miyagi, Ibaraki, Tochigi.

⁵ Radioactive contamination test – radioactive contamination inspection that was started in July 2011 as a preventive measure for exporting contaminated vehicles from Japan. The inspection is being conducted since in all sea ports of Japan under the supervision of The Japan Harbor Transportation Association (JHTA).

MLIT – Ministry of Land, Infrastructure, Transport and Tourism.

⁶ Japan New Car Assessment Program – the Ministry of Land, Infrastructure, Transport and Tourism (MLIT) and the National Agency for Automotive Safety & Victims' Aid (NASVA) have taken measures for safety, one of which is to assess commercially available vehicles through a variety of safety performance tests and release the resulting information compiled into the "New Car Assessment Program". The objective of Japan New Car Assessment Program is to increase the use of safe automobiles by providing an environment in which users can easily select such vehicles. This also promotes the development of safer vehicles by automobile manufacturers. Neck injury protection for rear-end collision performance test, rear seat passenger's protection for frontal collision performance test, rear passenger's seat belt usability evaluation test and seat belt reminder for passengers evaluation test are started in FY2009.

⁷ Braking Performance Tests – Braking performance is determined by the shortness of the distance in which a vehicle can stop and the stability of the vehicle at the time of braking. This test is performed under wet and dry road conditions for a vehicle which has both a driver and a front passenger. The distance it takes for the vehicle to stop and the stability of the vehicle at the time of braking is evaluated for when the vehicle is stopped abruptly while traveling at a speed of 100km/h. The stopping distance and vehicle speed have been measured by using GPS since FY2009.

CAR VX, LTD DEPENDS ON ITS SOURCES FOR THE ACCURACY AND RELIABILITY OF ITS INFORMATION. THEREFORE, NO RESPONSIBILITY IS ASSUMED BY CAR VX, LTD OR ITS AGENTS FOR ERRORS OR OMISSIONS IN THIS REPORT. CAR VX, LTD FURTHER EXPRESSLY DISCLAIMS ALL WARRANTIES, EXPRESS OR IMPLIED, INCLUDING ANY IMPLIED WARRANTIES OF MERCHANTABILITY OR FITNESS FOR A PARTICULAR PURPOSE.

© 2014-2023 Car VX Limited. All rights reserved.