

## VEHICLE DETAILS

**Chassis number <sup>1</sup>:** PG6SA-102145

**Manufacture date:** 1992-11

**Make:** MAZDA

**Model:** AUTOZAM AZ-1

**Body:** E-PG6SA

**Grade:** AZ-1

**Engine:** F6A

**Drive:** MIDSHIP

**Transmission:** F5

**Title information <sup>2</sup>:**



**Deregistered to Export**



**Accident / Repair:**



**Problem found**



**Odometer rollback:**



**No problem**



**Manufacturer recall:**



**No problem**



**Safety grade <sup>3</sup>:**



**No data**



**Contamination risk:**



**Problem found**



**This vehicle does not qualify for Buyback Guarantee**

**Average Market Price**



Unfortunately, this vehicle does not qualify for our Buyback Guarantee program.









**¥1,100,000**

[About Buyback Guarantee](#)

This CAR VX Vehicle History Report is based only on Information supplied to CAR VX, LTD and available as of 2022-10-03 16:00:35. Other information about this vehicle, including problems, may not have been reported to CAR VX, LTD . Use this report as one important tool, along with a vehicle inspection and test drive, to make a better decision about your next used car.

## ACCIDENT / REPAIR HISTORY

Problem type	Reported	Date reported	Data source	Details	Airbag
Collision	 Reported				
—	—	2022-05-28	ARAI Oyama VT	Repaired	OK
Malfunction	 Not reported				
Theft	 Not reported				
Fire damage	 Not reported				
Water damage	 Not reported				
Hail damage	 Not reported				

## ODOMETER READINGS HISTORY

Date reported	Data source	Odometer reading (Km)
2018-09-07	MLIT	51900
2020-09-04	MLIT	52400
2022-05-28	ARAI Oyama VT	52690
2022-06-02	USS Tokyo	52690

## USE HISTORY

<b>Use in the contaminated regions</b> <sup>4</sup>	<b>Radioactive contamination test fail</b> <sup>5</sup>	<b>Commercial use</b>
 Reported	 Not reported	 Not reported

## DETAILED HISTORY

Event date	Location	Odometer reading (Km)	Data source	Details
1992-11			MAZDA	Manufactured
1992-11			MLIT	First registration
2018-09-07		51900	MLIT	Inspection

2020-09-04		52400	MLIT	Inspection
2022-05-28	Tochigi	52690	ARAI Oyama VT	Auctioned
2022-06-02	Chiba	52690	USS Tokyo	Auctioned
2022-06-17	Chiba		MLIT	Last registration

## MANUFACTURER RECALL HISTORY

Date reported	Data source	Affected part	Details
 Not reported			

## VEHICLE ASSESSMENT <sup>6</sup>

### Overall Collision Safety Ratings

Driver's seat			Front passenger's seat		
Points	Evaluation	Goal average	Points	Evaluation	Goal average

\* In order to accurately differentiate between the evaluations of different vehicles, a standard is set based on current technology. Up to 6 points out of 12 is given level 1 and the rest of the range is divided up into equal parts, which are respectively assigned to level 2 (more than 6 points but 7.5 or less), level 3 (more than 7.5 points but 9 or less), level 4 (more than 9 points but 10.5 or less) or level 5 (more than 10.5 points).

### Braking performance tests <sup>7</sup>



## VEHICLE SPECIFICATION

1st gear ratio	2nd gear ratio
3rd gear ratio	4th gear ratio
5th gear ratio	6th gear ratio

<b>Additional notes</b>		<b>Airbag position, capacity</b>	
<b>Body rear overhang</b>		<b>Body type</b>	LIGHT CAR
<b>Chassis number embossing position</b>		<b>Classification code</b>	1
<b>Cylinders</b>	3	<b>Displacement</b>	650
<b>Electric engine type</b>		<b>Electric engine maximum output</b>	
<b>Electric engine maximum torque</b>		<b>Electric engine power</b>	
<b>Engine maximum power</b>	64ps(47kW)/6500rpm	<b>Engine maximum torque</b>	8.7kg· m(85.3N· m)/4000rpm
<b>Engine model</b>	F6A	<b>Frame type</b>	
<b>Front shaft weight</b>	300	<b>Front shock absorber type</b>	
<b>Front stabilizer type</b>		<b>Front tires size</b>	155/65R13 73H
<b>Front tread</b>	1200	<b>Fuel consumption</b>	
<b>Fuel tank equipment</b>	30	<b>Grade</b>	AZ-1
<b>Height</b>	115	<b>Length</b>	329
<b>Main brakes type</b>		<b>Make</b>	MAZDA
<b>Maximum speed</b>		<b>Minimum ground clearance</b>	
<b>Minimum turning radius</b>	4.7m	<b>Model</b>	AUTOZAM AZ-1
<b>Model code</b>	E-PG6SA	<b>Mufflers number</b>	
<b>Rear shaft weight</b>	420	<b>Rear shock absorber type</b>	
<b>Rear stabilizer type</b>		<b>Rear tires size</b>	155/65R13 73H
<b>Rear tread</b>	1195	<b>Reverse ratio</b>	
<b>Riding capacity</b>	2	<b>Side brakes type</b>	
<b>Specification code</b>	7155	<b>Stopping distance</b>	
<b>Transmission type</b>	F5	<b>Weight</b>	720
<b>Wheel alignment</b>	MIDSHIP	<b>Wheelbase</b>	2235
<b>Width</b>	139		

## AUCTION DATA

**Date: 2022-05-28, Auction: ARAI Oyama VT, Lot #: 21178**

Date:	2022-05-28	Lot #:	21178
Auction name:	<a href="#">ARAI Oyama VT</a>	Region:	Tochigi
Make:	MAZDA	Model:	AUTOZAM AZ-1
Reg. year:	2022	Mileage (km):	52690
Displacement (cc):	650	Transmission:	F5
Color:	actual vehicle	Model code:	PG6SA
Result:	unsold	Auction grade:	RA
Problem type:	Collision	Problem scale:	Repaired
Contaminated:	Yes	Airbag:	OK

**Date: 2022-06-02, Auction: USS Tokyo, Lot #: 679**

Date:	2022-06-02	Lot #:	679
Auction name:	<a href="#">USS Tokyo</a>	Region:	Chiba
Make:	MAZDA	Model:	AUTOZAM AZ-1
Reg. year:	1992	Mileage (km):	52690
Displacement (cc):	660	Transmission:	F5
Color:	RED	Model code:	PG6SA
Result:	available	Auction grade:	3
Problem type:	No problem	Problem scale:	None
Contaminated:	No	Airbag:	OK

## PHOTOS AND AUCTION SHEETS

出品 No.	初度登録 車名・ドア・形状・グレード					評価点
21178	4年 (月)	AZ-1				RA
	モデル年式	排気量	型式	最大積載量	乗車定員	内装 外装
	年	650 cc	E-PG6SA	/ kg	2/ 名	C C
車歴	シフト F5	セールスポイント				
車検 4年 9月	冷房 AC					
走行 * 52,690 km	燃料 G					
外装色 ケンヤ	色替	純正装備品	右ハンドル			
カラーNo. SU	後送品申告欄 (記載が無い場合、番号・機器無しと致します)					

**メーター改ざん車**

名義変更期限  迄  
R料金預託済額 6,240 円

◎走行に関する補足事項  
メーター改ざん

◎不具合箇所・注意事項

◎検査員報告

左Rサイドメンバー歪 右Rサイドメンバー歪小  
バックル XX 車内 各所外品取付  
下廻り A・U 各所下廻り S  
社外足廻り 社外マフラー  
社外アルミW 追加メーター  
外装 A・U  
Fガラストビ石  
室内ヨゴレ  
シートへたり  
ハンドルグリップスレ不良

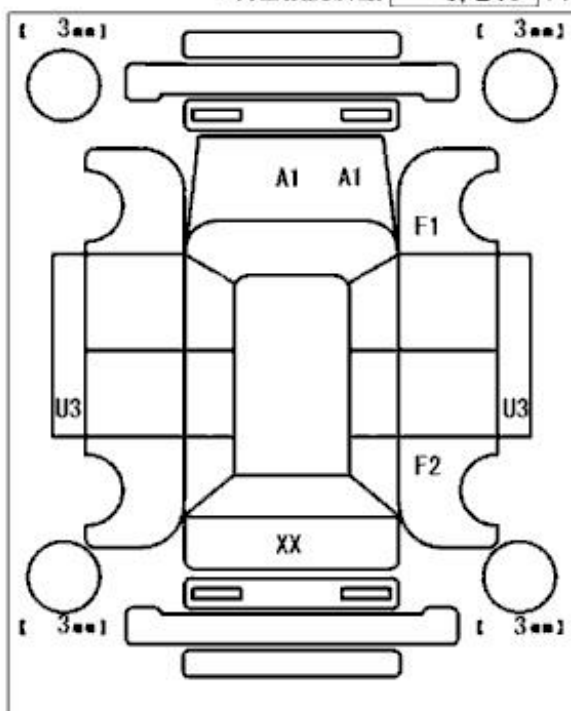

登録 No. とちぎ 580 木 6900

車台 No. PG6SA-102145







# 軽自動車コーナー

679	車種 (自動車以外は記入) 排気量	型式	PPID
	初年度登録年月 車名	グレード	3
4/月	AZ-1	E-PG6SA	内装 C

車検 4年9月	シフト FS	駆動方式 SR	AW	PS	PW
走行 52,690 Km	冷房 AC	カワ	TV	ナビ	IFB
外色 色調	カラー	セールスポイント			
内装色	有・無				
燃料 ガソリン・軽油	内装色				
輸入区分	ハンドル				
ディーラー・並行	左・右				

リサイクル料	6,240円	登録地	25C	580	ホ	6900
注視事項 (検査不具合箇所および状態等)		車台号	PG6SA-102145			
		シリアル号				

## 検査員報告 (USS使用欄)

5-1 7D)  
 ハンドル SL PL  
 2.0L 19 7020  
 2.0L 19 7020  
 2.0L 19 7020  
 2.0L 19 7020  
 2.0L 19 7020  
 2.0L 19 7020

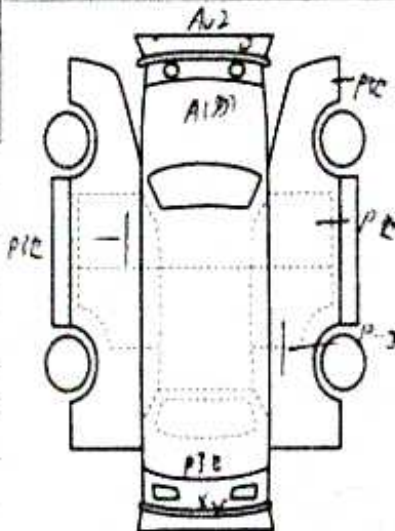

【荷台内寸】約	x	x	(cm)
長さ	幅	高さ	※ (車検上の寸法) スペア





**<sup>1</sup> Chassis number** – a unique identification number of the vehicle in Japan (same as VIN in the USA or Europe)

**<sup>2</sup> Title information:**

Registered – qualified for driving in Japan

Deregistered Temporarily – not qualified for driving in Japan, usually a temporary title during the ownership change

Deregistered Completely – not qualified for driving in Japan, the vehicle is determined to be scrapped

Deregistered to Export – not qualified for driving in Japan, the vehicle is determined to be exported

**<sup>3</sup> Determining the overall collision safety performance evaluation** – For the driver's seat, the results of the full-wrap frontal collision test, offset frontal collision test, and side collision test are added together and evaluated to 6 different levels. For the Frontal passenger's seat, the results of the full-wrap frontal collision test and the side collision test (results for the driver's or the front passenger's seat are used) are added together and evaluated to 6 different levels.

Regular vehicle inspection – All vehicles in Japan must undergo regular vehicle inspections (shaken). New cars need to be tested after three years, and then vehicles must be tested every two years thereafter. A vehicle inspection (shaken) is compulsory for all vehicles with an engine size over 250cc. It ensures that all vehicles on the road are properly maintained and safe to drive. The test also checks that vehicles have not been illegally modified; if they are found to have been modified, they are not allowed on the road.

**<sup>4</sup> Use in the contaminated regions** – The Fukushima Daiichi nuclear disaster was a catastrophic failure at the Fukushima I Nuclear Power Plant on 11 March 2011, resulting in a meltdown of three of the plant's six nuclear reactors. As a result, some areas in the following prefectures were contaminated: Fukushima, Miyagi, Ibaraki, Tochigi.

**<sup>5</sup> Radioactive contamination test** – radioactive contamination inspection that was started in July 2011 as a preventive measure for exporting contaminated vehicles from Japan. The inspection is being conducted since in all sea ports of Japan under the supervision of The Japan Harbor Transportation Association (JHTA).

MLIT – Ministry of Land, Infrastructure, Transport and Tourism.

**<sup>6</sup> Japan New Car Assessment Program** – the Ministry of Land, Infrastructure, Transport and Tourism (MLIT) and the National Agency for Automotive Safety & Victims' Aid (NASVA) have taken measures for safety, one of which is to assess commercially available vehicles through a variety of safety performance tests and release the resulting information compiled into the "New Car Assessment Program". The objective of Japan New Car Assessment Program is to increase the use of safe automobiles by providing an environment in which users can easily select such vehicles. This also promotes the development of safer vehicles by automobile manufacturers. Neck injury protection for rear-end collision performance test, rear seat passenger's protection for frontal collision performance test, rear passenger's seat belt usability evaluation test and seat belt reminder for passengers evaluation test are started in FY2009.

**<sup>7</sup> Braking Performance Tests** – Braking performance is determined by the shortness of the distance in which a vehicle can stop and the stability of the vehicle at the time of braking. This test is performed under wet and dry road conditions for a vehicle which has both a driver and a front passenger. The distance it takes for the vehicle to stop and the stability of the vehicle at the time of braking is evaluated for when the vehicle is stopped abruptly while traveling at a speed of 100km/h. The stopping distance and vehicle speed have been measured by using GPS since FY2009.

CAR VX, LTD DEPENDS ON ITS SOURCES FOR THE ACCURACY AND RELIABILITY OF ITS INFORMATION. THEREFORE, NO RESPONSIBILITY IS ASSUMED BY CAR VX, LTD OR ITS AGENTS FOR ERRORS OR OMISSIONS IN THIS REPORT. CAR VX, LTD FURTHER EXPRESSLY DISCLAIMS ALL WARRANTIES, EXPRESS OR IMPLIED, INCLUDING ANY IMPLIED WARRANTIES OF MERCHANTABILITY OR FITNESS FOR A PARTICULAR PURPOSE.

© 2014-2022 Car VX Limited. All rights reserved.